

Maglev Plus System

1. Description

The Maglev Plus System is specifically designed to levitate various objects attached to a very strong disc magnet or several other small magnets. The vertical position of the levitating magnet is measured using a linear Hall effect sensor and the magnetic force of an electromagnet is controlled using a microcontroller to achieve stable levitation. The system has three push buttons to adjust the controller parameters for each magnet and additional mass combination, and save the current controller parameters into the nonvolatile memory of the microcontroller.

2. Circuit Schematic

The circuit diagram of the system is as shown in Figure 1.

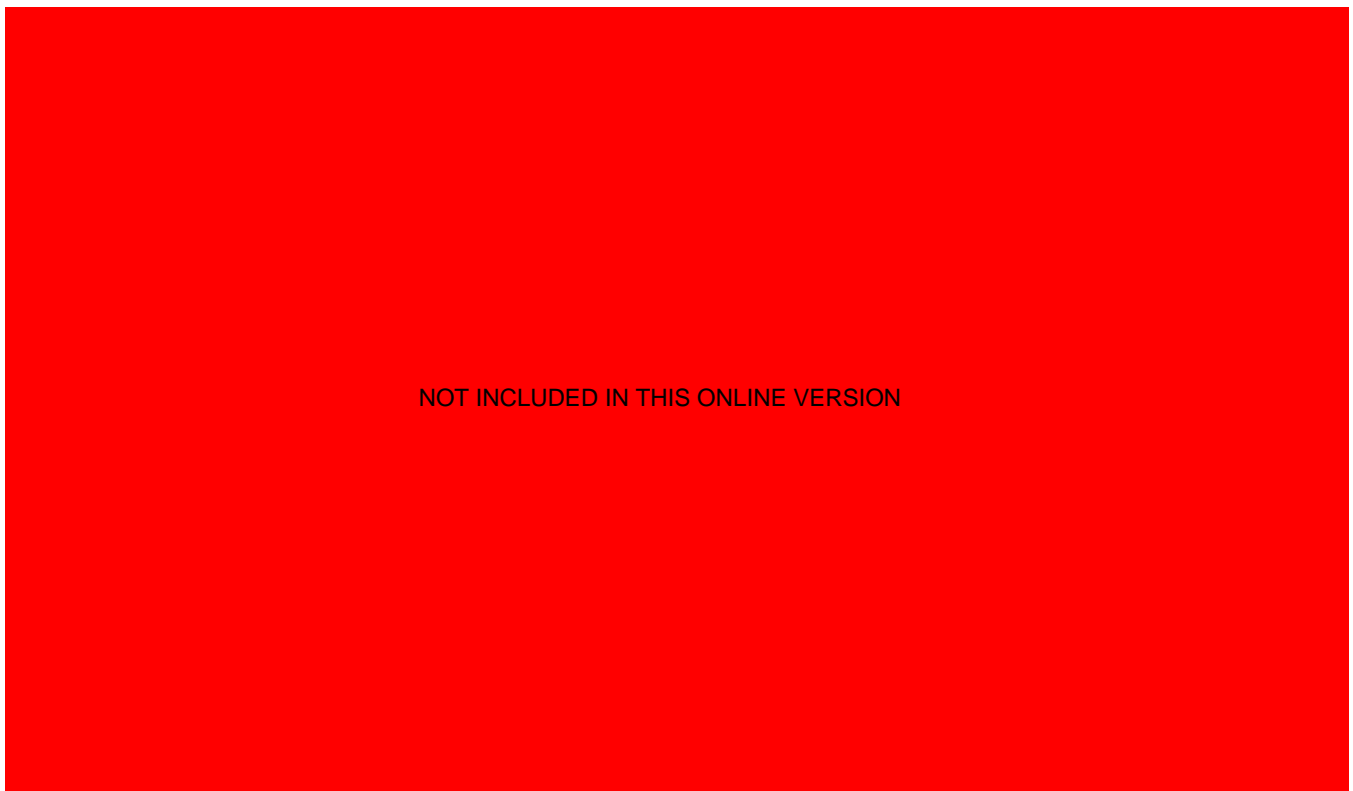

Figure 1. Circuit diagram of the system.

3. Operating Conditions

- Supply voltage range: 7.5 V DC
- Ambient temperature: 10 °C to 60 °C (50 °F to 140 °F)

4. Operating Instructions

Connect the 7.5 V DC power adapter to the system. The LED should light up when power is applied. Hold the levitating magnet about 2 cm (3/4") below the electromagnet while the power is on. The magnet will levitate if its orientation is correct. Otherwise, flip over the magnet and try again. The magnet will try to move away or turn over if the orientation is not correct.







The system has three push buttons labeled as A, B and C to adjust the controller parameters to achieve stable levitation with an additional object attached to the default magnet or other small magnets. The vertical equilibrium position of the levitating magnet and the electromagnetic force on the levitating magnet can be adjusted in 256 steps within a range by pressing the push button B (move the equilibrium position up or increase the electromagnetic force) and push button C (move the equilibrium position down or decrease the electromagnetic force). The push button B or push button C can be pressed and held down to make the adjustment faster. A heavier magnet and object combination requires more electromagnetic force to balance its weight.

The current controller parameters can be saved (up to 100000 times) into the nonvolatile memory of the microcontroller by pressing the push button A approximately 8 s if desired. The LED will flash 4 times to indicate that the current configuration is saved (do not power down the system during this operation until the LED is continuously on). If the current configuration is not saved, then it will be lost when the power is cycled.













5. Kit Assembly

















The electromagnetic levitation kit requires both electrical and mechanical assembly. The assembly instructions are detailed below.

5.1. Items Required (not included)

screw driver 	diagonal cutter 	needle-nose pliers 	super glue 
soldering iron 	solder wire 		

5.2 Parts Included

1 x PIC12F1571  U1	1 x LM78L05 5 V regulator  U2	1 x OH49E Hall effect sensor  U3	1 x NTD4963N MOSFET  Q1
1 x 1N5817 Schottky diode  D1	1 x LED  LED	1 x 1 kΩ resistor  R1	1 x 15 mH inductor (coil)  L1
3 x 100 nF capacitor (104)  C1, C2, C5	1 x 1 μF capacitor (105)  C3	1 x 10 μF capacitor (106)  C4	3 x tactile switch  A, B, C

<p>1 x power jack</p>  <p>PWR</p>	<p>1 x 2 pin header</p>  <p>COIL</p>	<p>1 x 3 pin header</p>  <p>SENS</p>	<p>1 x 2-conductor cable</p>  <p>K1</p>
<p>1 x 7.5 V power adapter</p>  <p>V1</p>	<p>1 x 2" x 2" PCB</p>  <p>P1</p>	<p>1 x aluminum base</p>  <p>A1</p>	<p>1 x aluminum piece</p>  <p>A2</p>
<p>4 x nylon spacer</p>  <p>H1, H2, H3, H4</p>	<p>6 x 4-40 screw</p>  <p>S1, S2, S3, S4, S5, S6</p>	<p>1 x flat-top screw</p>  <p>S7</p>	<p>1 x screw with anchor</p>  <p>N1</p>
<p>1 x magnet</p>  <p>M1</p>	<p>4 x self-adhesive rubber</p>  <p>F1, F2, F3, F4</p>	<p>1 x self adhesive rubber</p>  <p>F5</p>	<p>1 x clear plastic piece</p>  <p>P1</p>

5.3 Assembly Instructions

Electrical assembly

- Mount the components U1, U2, Q1, D1, R1, C1, C2, C3, C4, C5, A, B, C, LED, PWR connector, COIL header and SENS header on the PCB as shown in Figure 2. The orientations of U1, U2, Q1, D1 and LED are important and they should be mounted according to their footprints on the top side of the PCB. The orientations of R1, C1, C2, C3, C4 and C5 are not important.
- Solder each component carefully and trim its leads if necessary using the diagonal cutter.
- Solder the 2-conductor cable to the coil (the blue cable to the outer lead and the red cable to the inner lead).

Mechanical assembly

- Stick the rubber feet under the base aluminum block to prevent it from scratching, and mount the PCB on top of the base using 4 x 4-40 machine screws and 4 nylon spacers as shown in Figure 3.
- Fasten the L-shaped aluminum piece to the base block using 2 x 4-40 machine screws as shown in Figure 3.
- Fasten the coil using the screw and anchor as shown in Figure 3.
- Glue the wider side of the Hall effect sensor to the bottom of the coil symmetrically by using the clear plastic piece in between the coil and sensor.
- Stick the self adhesive rubber to the bottom of the coil to protect both the Hall effect sensor and coil.

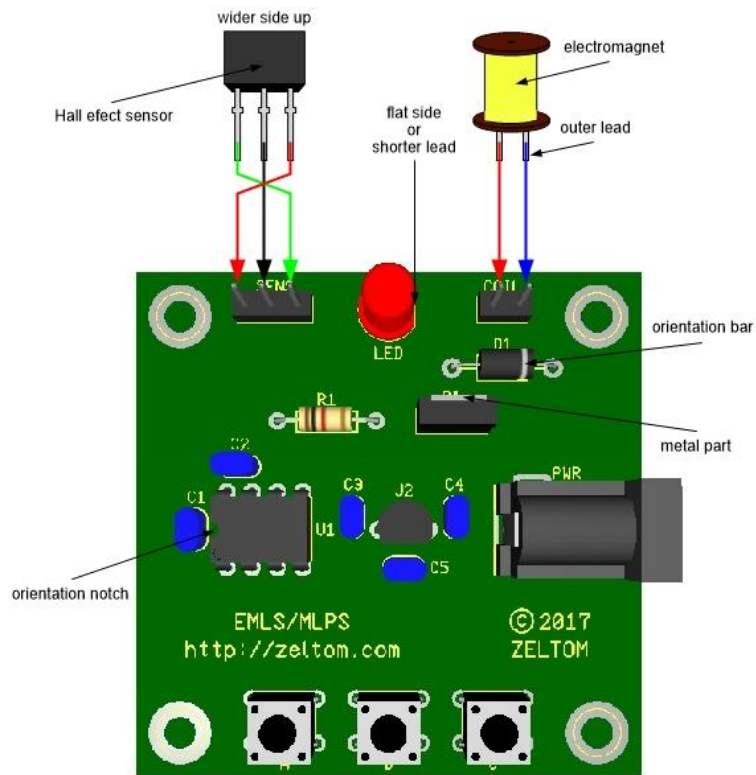

Figure 2. Electrical assembly.

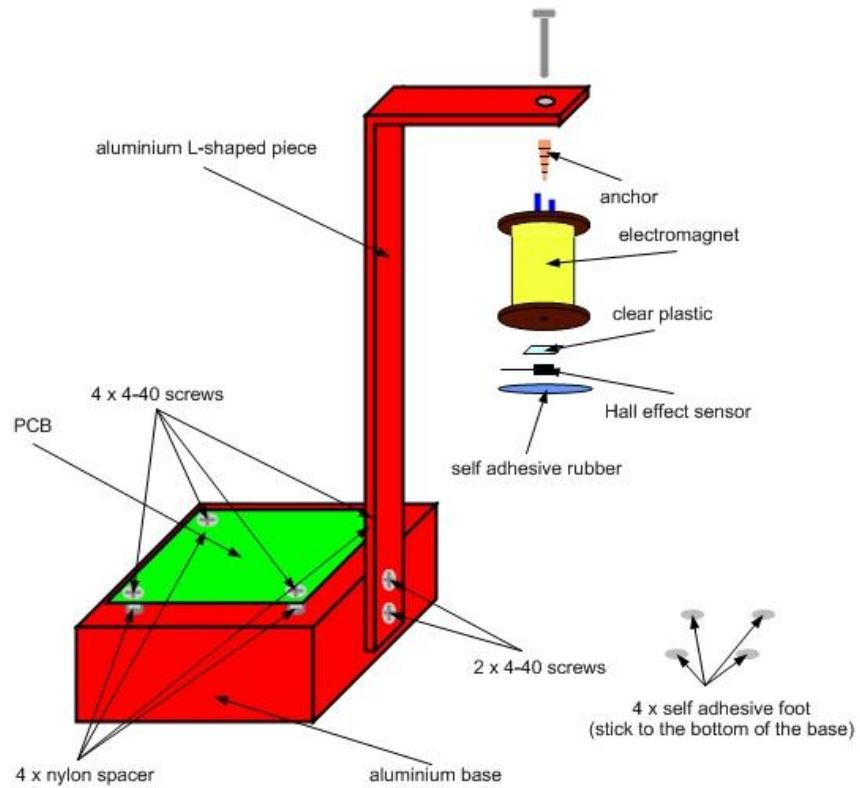

Figure 3. Mechanical assembly.

6. Calibration

The system can be calibrated (up to 100000 times) to eliminate slight sensor misalignment that may occur during the mechanical assembly in a special calibration mode. The calibration mode is activated if the button A is pressed and held before applying power to the system, and then released. The LED flashes 4 times to indicate that the system is calibrated and calibration data is saved into the nonvolatile flash memory of the microcontroller. The magnet must be kept far away from the system during the calibration mode until the LED turns continuously on.

7. Troubleshooting

- Make sure that the electrical and mechanical components are assembled correctly.
- Check the sensor and coil cables and ensure that they are connected correctly.
- If the LED is not lit, check the power adapter connections.
- If the LED is lit but the magnet does not levitate, use the push buttons to adjust the controller.